

Produkt Datenblatt

Gerätebezeichnung: RAS-M16U2DVG-E

Technische Daten

	Einheiten	Werte
Nennkühlleistung	kW	4,5
Nennheizleistung	kW	5,5
Luftvolumenstrom (h/n) C	m ³ /h	780 - 420
Schalldruckpegel (h/n) C	dB (A)	36 / 22
Luftvolumenstrom (h/n) H	m ³ /h	780 - 450
Schalldruckpegel (h/n) H	dB (A)	36 / 23
Abmessungen (HxBxT)	mm	210 x 900 x 450
Gewicht	kg	19
Bördelanschlüsse - Einspritz	mm	¼"
Bördelanschlüsse - Gas	mm	½"
Pressung	Pa	10 - 45
Kondensatanschluss	DN	25

Abbildung:



Maßskizze:

4. CONSTRUCTION VIEWS

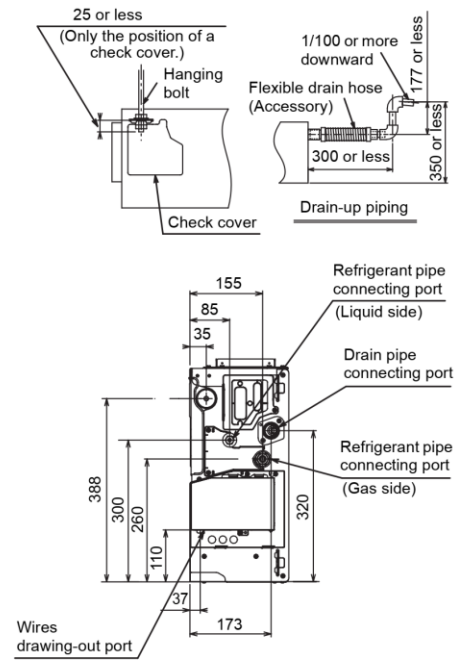
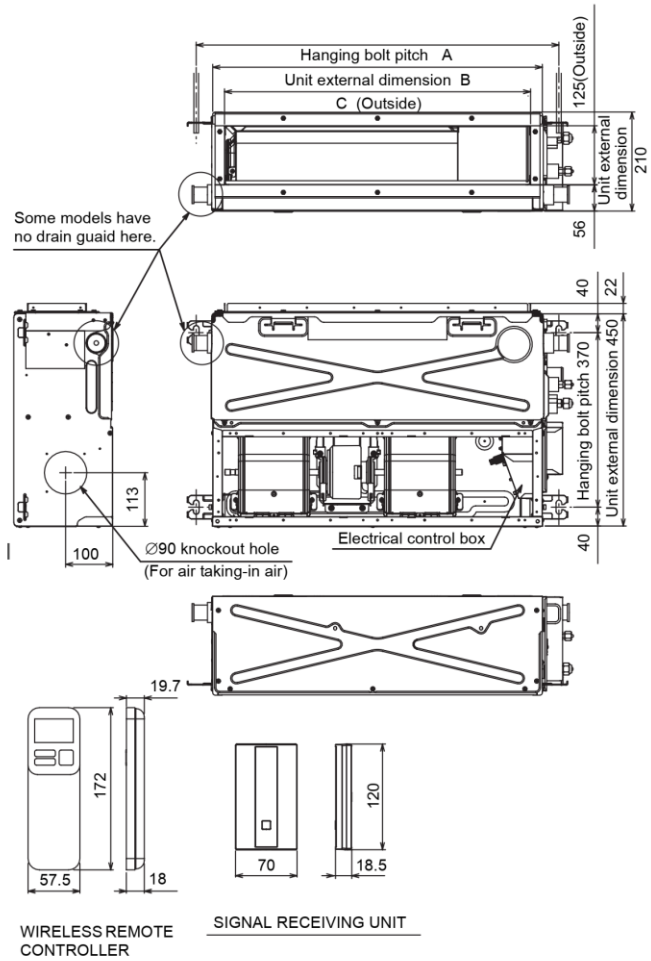

	A	B	C
07,13 type	770	700	650
16 type	970	900	850
22,24 type	1,170	1,100	1,050